



TS3019

WIRELESS TALLY SYSTEM

USING THE UNIT SAFELY

Before using this unit, please read below warning and precautions which provide important information concerning the proper operation of the unit. Besides, to assure that you have gained a good grasp of every feature of your new unit, read below manual. This manual should be saved and kept on hand for further convenient reference.



Warning And Cautions

- ※ To avoid falling or damage, please do not place this unit on an unstable cart, stand, or table.
- ※ Operate unit only on the specified supply voltage.
- ※ Disconnect power cord by connector only. Do not pull on cable portion.
- ※ Do not place or drop heavy or sharp-edged objects on power cord. A damaged cord can cause fire or electrical shock hazards. Regularly check power cord for excessive wear or damage to avoid possible fire / electrical hazards.
- ※ Do not operate unit in hazardous or potentially explosive atmospheres. Doing so could result in fire, explosion, or other dangerous results.
- ※ Do not use this unit in or near water.
- ※ Do not allow liquids, metal pieces, or other foreign materials to enter the unit.
- ※ Handle with care to avoid shocks in transit. Shocks may cause malfunction. When you need to transport the unit, use the original packing materials or alternate adequate packing.
- ※ Do not remove covers, panels, casing, or access circuitry with power applied to the unit! Turn power off and disconnect power cord prior to removal. Internal servicing / adjustment of unit should only be performed by qualified personnel.
- ※ Turn off the unit if an abnormality or malfunction occurs. Disconnect everything before moving the unit.

Note: due to constant effort to improve products and product features, specifications may change without notice.

CONTENT

1. Brief Introduction	1
1.1 Overview	1
1.2. Main Features	1
2. Interfaces	2
2.1 Interfaces	2
2.2 GPIO Definition	4
2.3 RS-485 Definition	5
2.4 Transmitter GPIO input interface diagram(Tally box)	6
2.4 Tally output interface diagram(Tally lamp)	6
3. Specification	6
4. DIP Functions	8
5. Operation Instruction	10
5.1 Wireless Tally connection	10
5.2 Wired Tally Connection	13
5.3 Remote serial control (PTZ camera remote control)	13
6. Accessories	13

1. Brief Introduction

1.1 Overview

TS3019 is a wireless tally system, which is an auxiliary system that indicates the current broadcast position (red light) and the upcoming position (green light) of the camera operator, host and other related personnel through the tally indicator red and green, relaying information in real time. The wireless tally system is suitable for interview programs, performances, sports, live weddings, churches and other live broadcast activities.

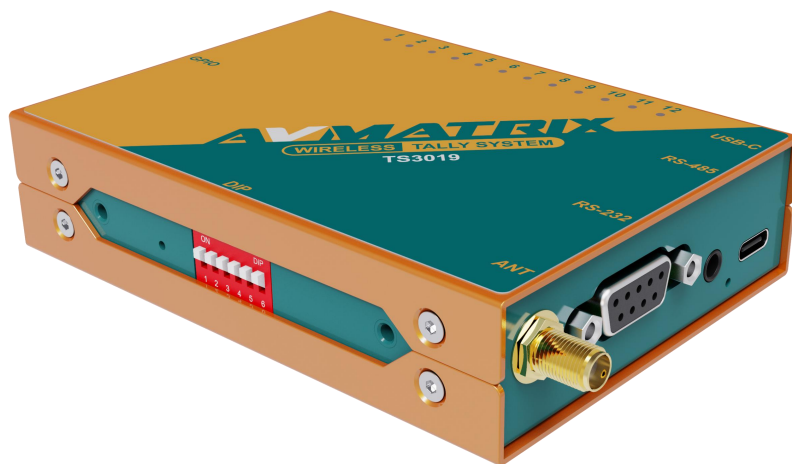

1.2. Main Features

TALLY BOX

- Up to 200m wireless connection distance (line-of-sight)
- The tally box with multiple interfaces including GPIO/USB/RS-485/RS-232
- GPIO compatible with AVMATRIX and other video switchers
- Compatible with VMix via USB-C
- RS-232/RS-485 support TSL protocol Tally input and one-way transmissive control information
- Support 433Mhz wireless Tally connection and RS-485 wired Tally connection

TALLY LAMP

- Tally lamp can be powered by Micro-USB or 18650 li-ion battery
- Both front and rear indicator on the lamps with 4-level adjustable brightness, the brightness up to 2000cd/m²
- Visible signal strength and battery status on the tally lamp
- 1/4 inch hot shoe for tally lamp installation
- Support remote PTZ camera control via RS-232/RS-485

2.Interfaces

2.1 Interfaces

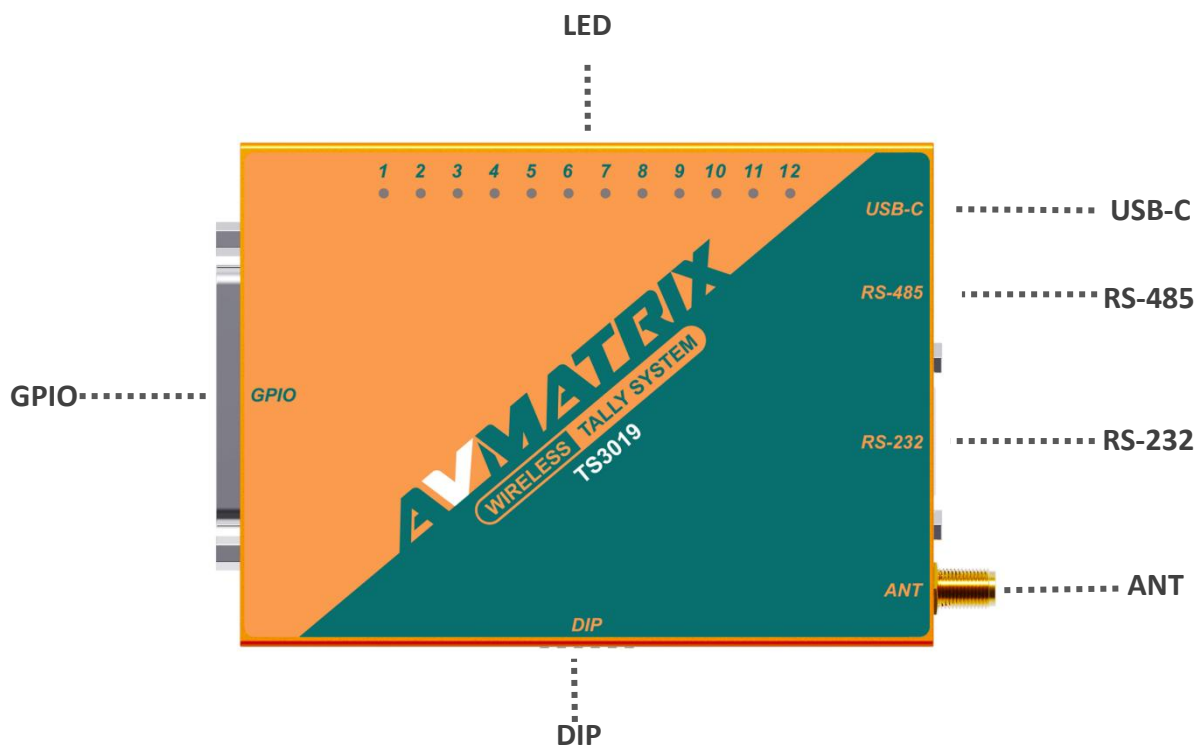

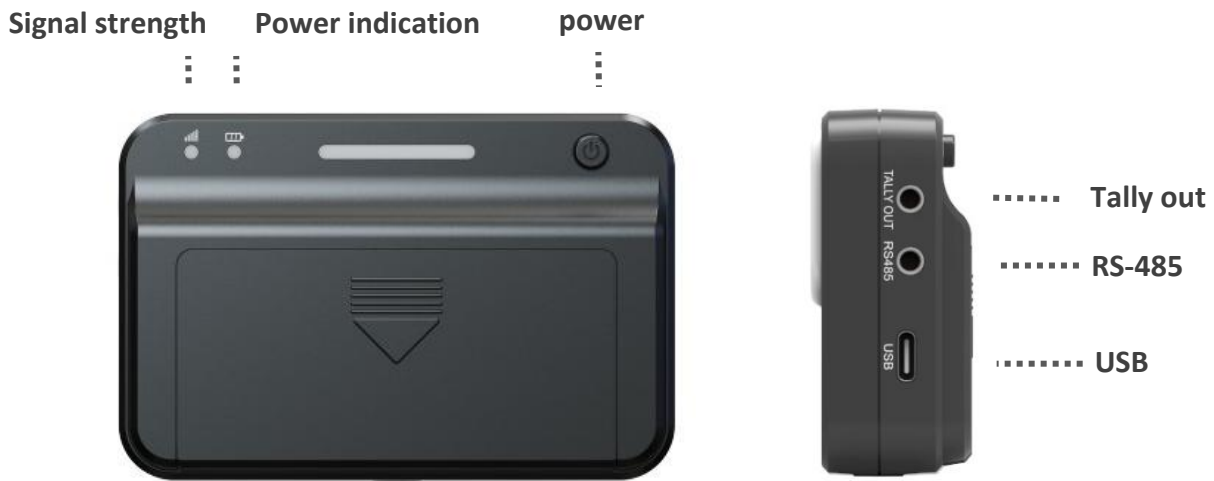

Short press the power button to adjust the brightness of the light, long press the power button to turn the power on and off.

Note: Signal strength indication: when the signal is strong the signal indicator shows green, when the signal is moderate the indicator shows yellow, and when the signal is weak the indicator shows red.

Power indication: when the power is sufficient the indicator shows green, when the power is average the indicator shows yellow, when the power is low, the indicator shows red, and when charging the power indicator flashes, when charging is complete, the power indicator stops flashing and the green light is always on.

About the battery:

It supports 18650 rechargeable lithium battery.

Please note that the batteries need to be used with a positive terminal with a foil protrusion. If the positive terminal of the battery does not have a foil protrusion but is flat, it will not make contact with the tally lamp, rendering it inoperable. as shown in the picture below:

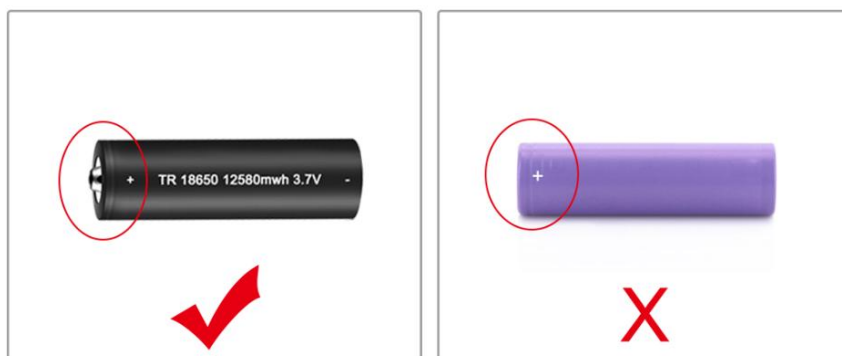

2.2 GPIO Definition

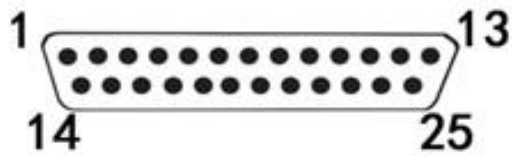

GPIO	Definition	GPIO	Definition
1	GND Grounded	14	PVW12 green Tally12
2	PGM12 red Tally12	15	PVW11 green Tally11
3	PGM11 red Tally11	16	PVW10 green Tally10
4	PGM10 red Tally10	17	PVW9 green Tally9
5	PGM9 red Tally9	18	PVW8 green Tally8
6	PGM8 red Tally8	19	PVW7 green Tally7
7	PGM7 red Tally7	20	PVW6 green Tally6
8	PGM6 red Tally6	21	PVW5 green Tally5
9	PGM5 red Tally5	22	PVW4 green Tally4
10	PGM4 red Tally4	23	PVW3 green Tally3
11	PGM3 red Tally3	24	PVW2 green Tally2
12	PGM2 red Tally2	25	PVW1 green Tally1
13	PGM1 red Tally1		

2.3 RS-485 Definition

The Tally transmitter and receiver RS-485 pins are defined as follows.

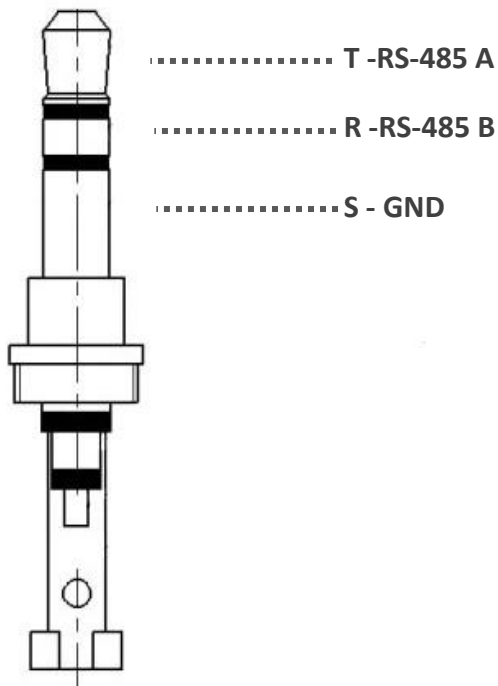

The Tally output pins on the receiver side are defined as follows.

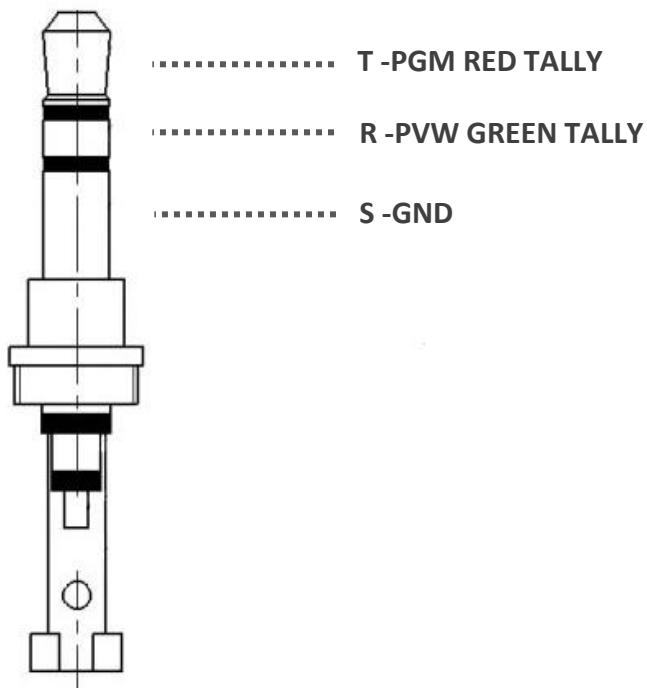

2.4 Transmitter GPIO input interface diagram(Tally box)

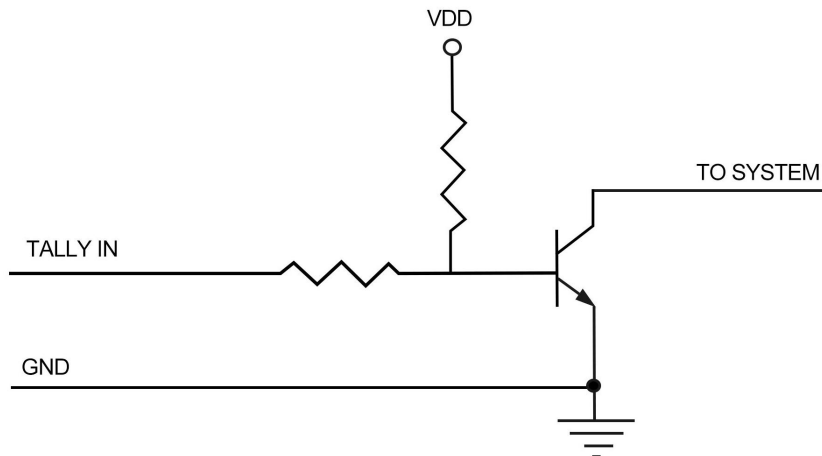

2.4 Tally output interface diagram(Tally lamp)

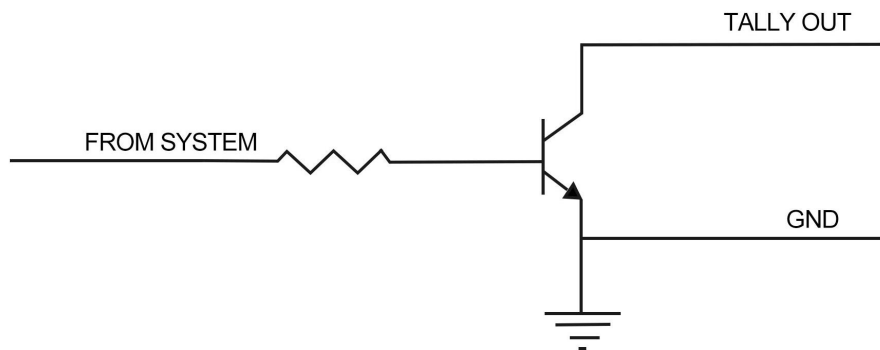

3.Specification

TALLY BOX PARAMETERS	Connections	1×GPIO, 1×RS-232, 1×RS-485, 1×USB type-c
	Number of Lamps	Support up to 16 tally lamps (12 LED lamp)
	Wireless Distance	Transmission up to 200m (line-of-sight)
	Wireless Connectivity	433MHz
	Wired Connectivity	RS-485 serial connection
	Application Support	Video switchers with GPIO-tally interface such as AVMATRIX ,Roland, SONY, NewTek, Panasonic, DataVideo, or tally converter box with GPIO such as BMD's GPI and tally interface

	Power	Working Voltage: 5V, Power Consumption: $\leq 0.2W$
TALLY LAMP PARAMETERS	Connections	1×USB Type-c, 1×RS-485, TALLY OUT
	Power supply	5V USB power supply or 18650 lithium battery (optional) power supply
	Brightness	Support 4-level brightness
	Battery Operating Time	up to 9 hours (depending on battery capacity & lamp brightness & usage environment)
	Power	Working Voltage: 5V; Power Consumption: $\leq 2.5W$; Battery Charging Current: 5V 1A
	Mouting Hole	1/4 inch hotshoe hole
OTHERS	Dimension (LWD)	Tally box: 104*75.5*24.5mm Tally lamp: 98.5*65*26.5 mm
	Weight	Tally box: 327g Tally lamp: 90g (without battery)
	Temperature	Working temperature: $-20^{\circ}C \sim 60^{\circ}C$ storage temperature: $-30^{\circ}C \sim 70^{\circ}C$
	Accessories	Tally box: 1×power supply (5V 1A) , 1×USB2.0 type-c cable, 1×antenna, 1×GPIO connector Tally lamp: 1×USB2.0 type-c cable

4.DIP Functions

The dip switch of Tally box provides the following settings:

WIRELESS TALLY SYSTEM						
DIP (1=ON, 0=OFF)						
INPUT	SW1	SW2	RS-485	SW3	GROUP	SW5
GPIO	1	1	Input	1	Group 1	1
USB-C	1	0	Output	0	Group 2	0
RS-485	0	1	MODE	SW4	USB-C	SW6
RS-232	0	0	DIP	1	Working	1
			PC	0	Config	0

1.DIP SW 1-2

This switch is used to select the input interface.

when (SW1,SW2) is set to (1,1), GPIO input is selected.

when (SW1,SW2) is set to (1,0), USB-C input is selected.

2.DIP SW 3

This switch is used to select the input and output of the RS-485 interface.

When set to 1, RS-485 is selected as input, and when set to 0, RS-485 is selected as output.

The RS485 is configured as an output when a wired connection is required between the tally box and tally lamp.

3.DIP SW 4

This switch is used to set the switch selection control between DIP and the PC software.

When set to 1, it works according to the current DIP configuration parameters; when set to 0, DIP parameters are invalid and the built-in parameters configured by the PC software are used.

4.DIP SW 5

This switch is used to set the group of tally box.

When set to 1, group 1 is selected, and when set to 0, group 2 is selected.

Note: The transmitter and receiver of the same group should be set in the same cluster.

This function is used when more than one tally is needed to work at the same time on the same occasion (within a 1km radius) to prevent the signals of different groups from interfering with each other. The factory default is group 1. When the signal is not received, check whether the TX and RX group settings are the same group. DIP can be configured for two groups, the software can be configured for up to 8 groups.

5.DIP SW 6

This switch is used to select the operating state of the USB-C interface. When set to 1, USB-C interface is in working state, and when set to 0, USB-C interface is in configuration state and used to connect to the computer to control the software configuration parameters.

The dip switches for the Tally lamp provide the following settings:

DIP 1 (1=ON, 0=OFF)					DIP 2 (1=ON, 0=OFF)	
LAMP	SW1	SW2	SW3	SW4	INPUT	SW1
NO. 1	0	0	0	0	Wireless	1
NO. 2	1	0	0	0	RS-485	0
NO. 3	0	1	0	0	MODE	SW2
NO. 4	1	1	0	0	DIP	1
NO. 5	0	0	1	0	PC	0
NO. 6	1	0	1	0	GROUP	SW3
NO. 7	0	1	1	0	Group 1	1
NO. 8	1	1	1	0	Group 2	0
NO. 9	0	0	0	1		
NO. 10	1	0	0	1		
NO. 11	0	1	0	1		
NO. 12	1	1	0	1		

1.DIP1 SW 1-4

This switch is used to set the number of the Tally lamp. The channel corresponding to the Tally input.

2.DIP2 SW 1

This switch is used to set the connection type of tally lamp. When SW1 is set to 1, tally lamp is wirelessly connected and lights up by receiving tally information from the wireless transmitter of tally box, and when SW1 is set to 0, tally lamp is wired and lights up by RS485 connection to tally box.

3.DIP2 SW2

This switch is used to set the switch selection control between DIP and the PC software. When set to 1, it works according to the current DIP configuration parameters; when set to 0, DIP parameters are invalid and the built-in parameters configured by the PC software are used.

4.DIP2 SW3

This switch is used to set the group of tally lamp.

5.DIP2 SW4

This switch serves as a reserved key and has no function.

5.Operation Instruction

5.1 Wireless Tally connection

- Video switcher connection

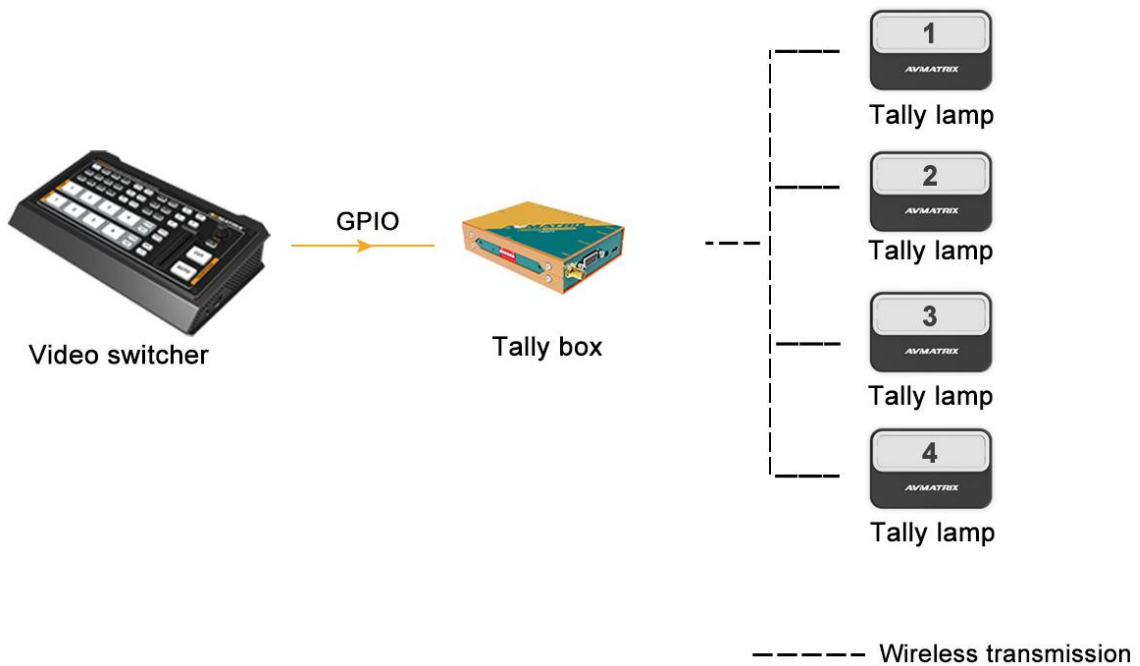

● Vmix connection

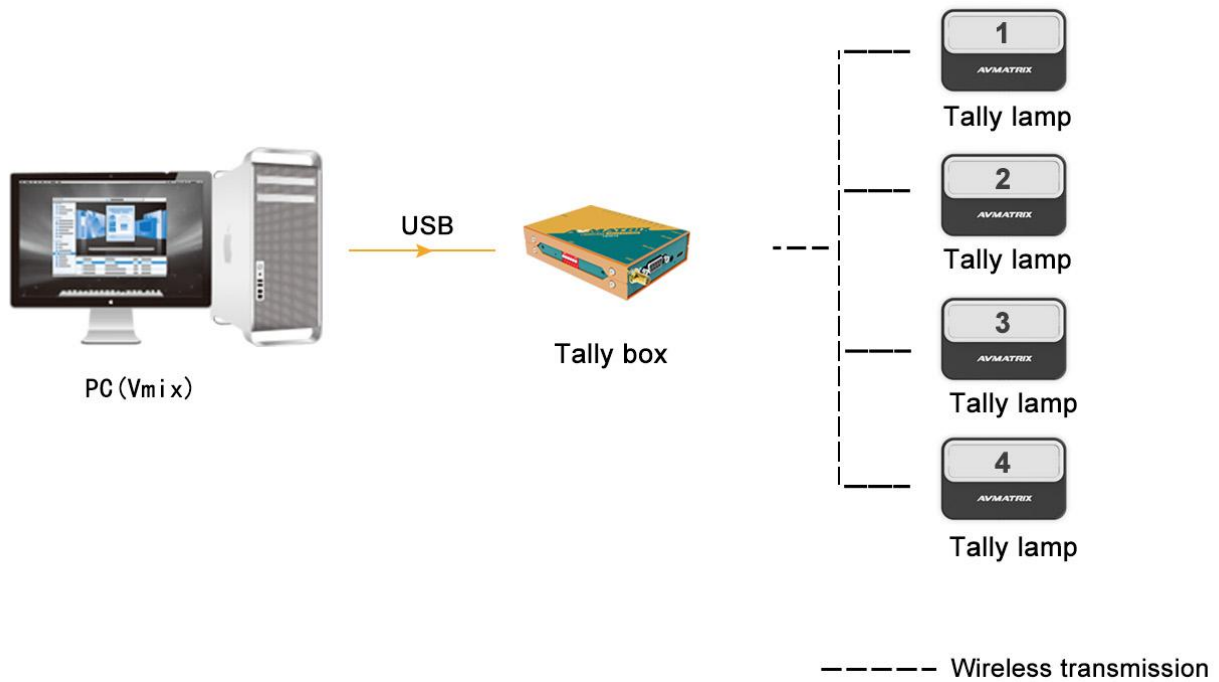

Vmix Connect TS3019:

Step 1: Configure Tally box and Tally lamp

Set the input of Tally box to USB-C (SW1:1, SW2:0). Set the Tally lamp to 1, 2, 3, 4 respectively.

Step 2: Use a USB A to C cable to connect the USB Type C port of the Tally box and the USB-A port of the PC. Look at the Device Manager on the PC to check the status of the COM port connected to the Tally box. The figure below shows COM3.

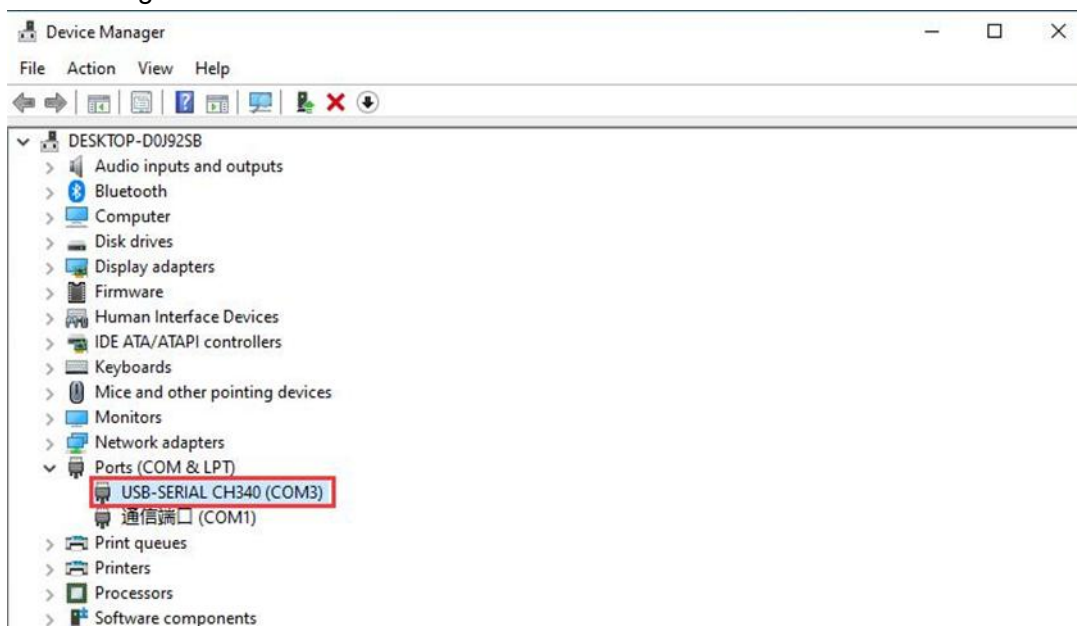

Step 3: Set up Vmix software

Open the Vmix setup, click Tally Lights and reset to default mode as shown below.

Users can increase PIN according to the actual number of Tally lamp. (For example, if you want to connect 6 Tally lamps, you need to fill in PreviewPIN and ActivePIN in order from 2.3 of the lamp 1 to the lamp 6 according to the rules, and then click to confirm), as shown in the following figure.

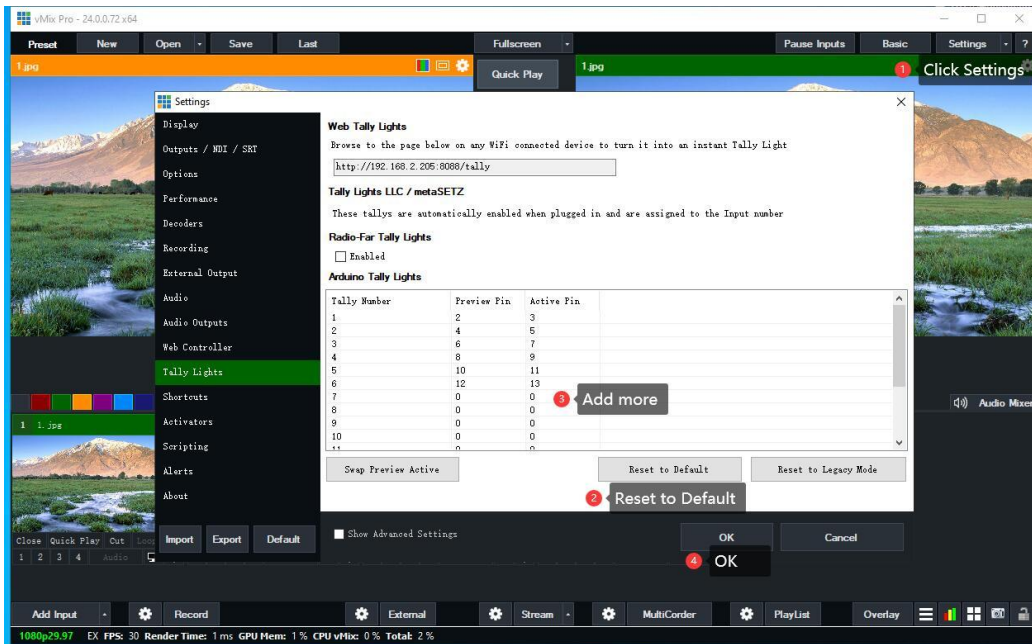

Step 4: Connection

Double click each input , click Tally Lights, select the COM port status , Tally Number select the Tally lamp corresponding to the input source, and you can finish configuring the connection.

(The COM port status as shown below is COM3, Tally Number selects lamp 1, indicator 1 on Tally box lights up, lamp 1 will also light up, that is, the connection.)

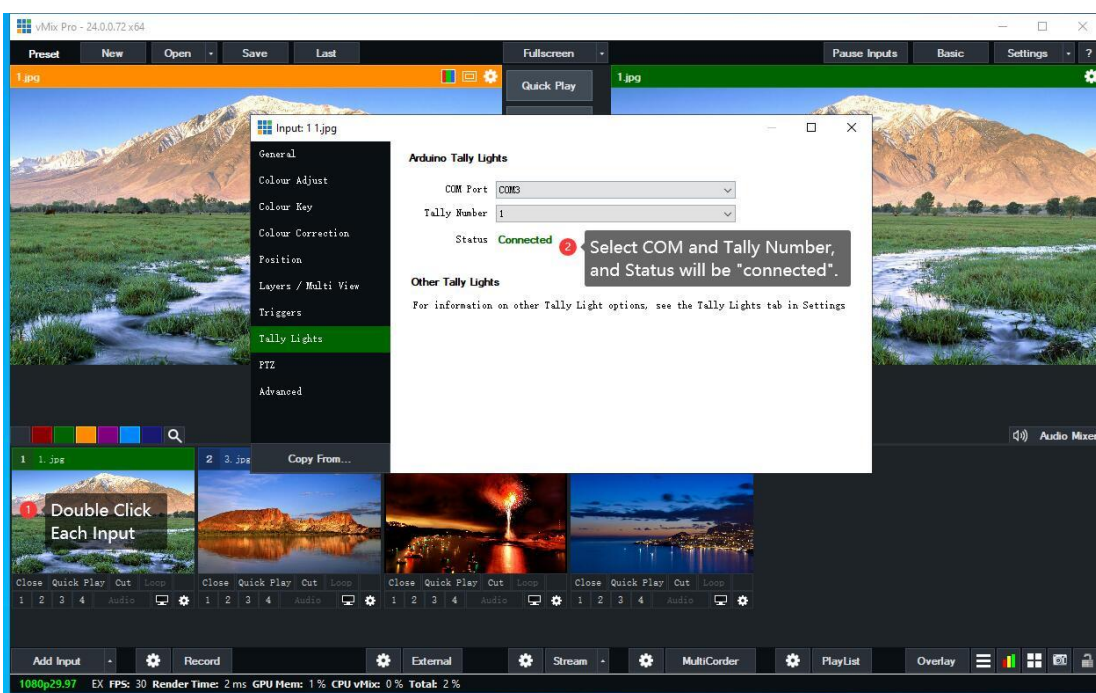

5.2 Wired Tally Connection

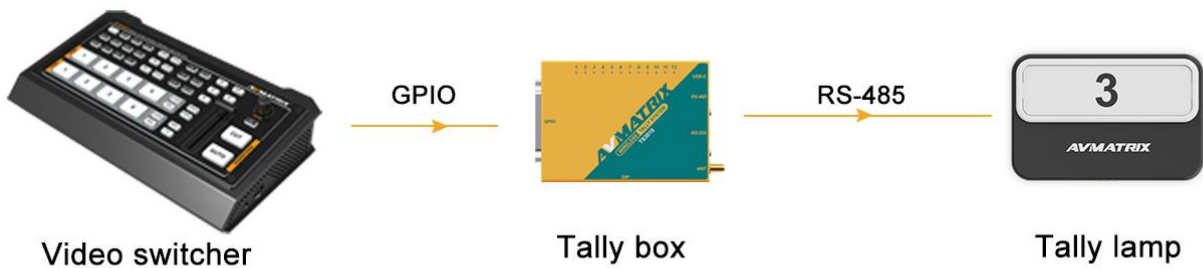

5.3 Remote serial control (PTZ camera remote control)



6. Accessories

The Tally box is equipped with 1× power adapter (5V 1A) , 1× antenna, 1× USB2.0 type-c cable, 1× GPIO connector, and the Tally lamp is equipped with 1× USB2.0 type-c cable.

