

dji SDR TRANSMISSION

User Guide

v1.0 2024.07

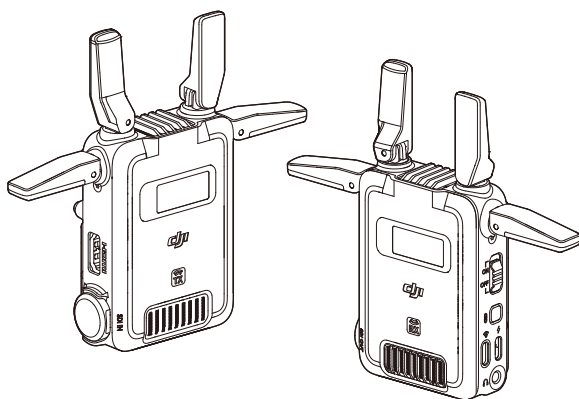

Disclaimer

Carefully read this entire document and all safety and compliance guidelines provided before use.

Contents

1	Product Profile	4
1.1	Introduction	4
1.2	Overview	4
2	Power Supply	7
2.1	Power Supply via NP-F Battery	7
2.2	Power Supply via USB-C	7
2.3	Power Supply via Gimbal	8
3	Firmware Update and Device Activation	9
4	Touchscreen	10
4.1	Home Screen	10
	Transmitter	10
	Receiver	11
4.2	Menu	11
	Transmitter Menu	11
	Receiver Menu	12
4.3	Channel Selection	13
4.4	Wi-Fi Connection	14
5	Connection Mode	15
5.1	Control Mode	15
5.2	Broadcast Mode	15
5.3	Wi-Fi	16
5.4	Recommended Connection Schemes	17
6	Ronin App	19
6.1	Downloading Ronin App	19
6.2	Installation and Connection	19
6.3	Connecting to Transmitter	20
6.4	Camera View	21
7	Accessories	25
7.1	TX Camera Mounting Adapter Plate	25
7.2	Phone Holder (Sold Separately)	25
7.3	Tablet Holder (Sold Separately)	26
8	Specifications	28

1 Product Profile

1.1 Introduction

DJI™ SDR Transmission is a wireless transmission system featuring DJI SDR video transmission technology. DJI SDR Transmission features modes such as SDR mode and Wi-Fi mode, offering you a more cost-effective monitoring solution. Control mode and Broadcast mode are supported using SDR signal transmission. In Control mode, you can connect one transmitter to two receivers, allowing seamless auto frequency hopping and dynamic bitrate adjustments, which ensure ultra-long-range transmission and strong interference resistance. In Broadcast mode, you can connect one transmitter to an unlimited number of receivers, allowing multiple receivers to monitor within a close range simultaneously. Wi-Fi mode allows one transmitter to connect up to two mobile devices at the same time, which is suitable for temporary monitoring.

In addition to connecting to the monitor via HDMI and SDI ports, DJI SDR Transmission also supports connecting mobile devices via USB-C port or Wi-Fi and monitoring via the Ronin app. The Ronin app also provides professional monitoring assistance tools and supports functions such as gimbal control and camera control. You can log in to your accounts to sync the footage to the Filming app.

1.2 Overview

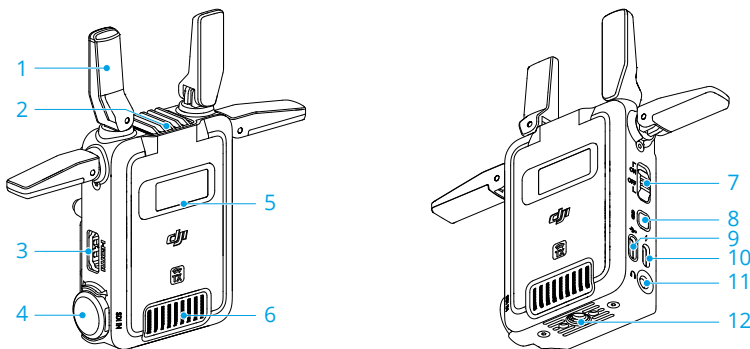

Transmitter

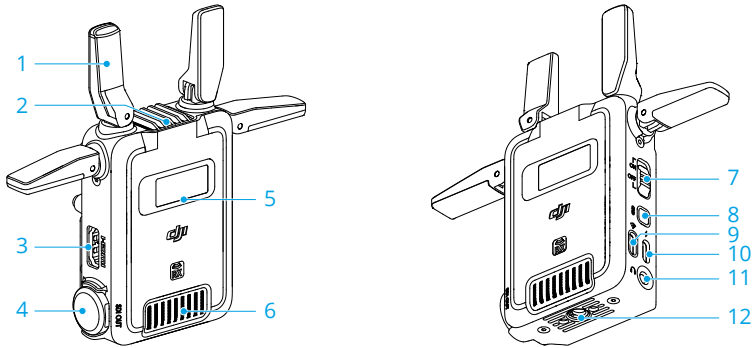

Receiver

1. **Foldable antennas**

⚠ • The antennas are not detachable.

2. **Air Intake**

⚠ • DO NOT cover the air vent. Otherwise, the performance of the device may be affected due to overheating.

3. **HDMI Input (Transmitter):** For receiving the video signal output from the camera.

HDMI Output (Receiver): For outputting the received video signal to the monitor.

4. **SDI Input (Transmitter):** For receiving the video signal output from the camera.

SDI Output (Receiver): For outputting the video signal to the monitor.

5. **Touchscreen**

Displays the device status and menu settings.

6. **Air Outlet**

⚠ • DO NOT cover the air vent. Otherwise, the performance of the device may be affected due to overheating.

7. **Power Switch**

8. **Link Button**

Press once to lock or unlock the screen. Press and hold to enter the linking status.

9. **USB-C Firmware Update Port (Transmitter)**

USB-C Firmware Update and Video Output Port (Receiver)

For device activation and firmware updates.

The port on the receiver can also be used to transmit videos. When used with the Ronin app, the port can output the received video signal to a mobile device.



- Mobile devices that do not support the DP function via the USB-C port cannot connect to the receiver for video transmission.



- For details on smartphones and tablets compatible with the Ronin app, refer to the [Ronin App Compatibility List](#).
-

10. USB-C Power and Gimbal Communication Port (Transmitter)

USB-C Power Port (Receiver)

Connect to an adapter for power supply via a USB-C cable.

The USB-C Power and Gimbal Communication Port on the transmitter can also be connected to the video transmission/LiDAR range finder port (USB-C) of the gimbal via the camera control cable (USB-C, 30 cm) to communicate with the gimbal and achieve gimbal control.

11. 3.5mm Stereo Jack

When the receiver is linked to the transmitter in Control mode, direct and real-time two-way communication is enabled via the headset.



- Headset compatibility may vary, certain models may experience some issues. For details, refer to the [Headset Compatibility List](#).
-

12. 1/4" Screw Hole

2 Power Supply

2.1 Power Supply via NP-F Battery

Before first use, unfold the antennas and install the NP-F battery. Insert the NP-F battery into the battery slot and push it to the end. Make sure that the battery release button pops up, indicating the battery is firmly in place. Press and hold the release button and push the battery in the opposite direction to remove it.

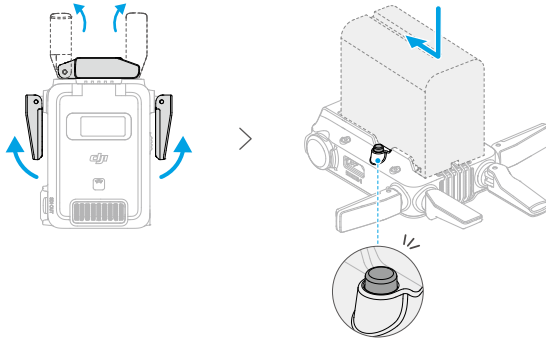

2.2 Power Supply via USB-C

In addition to using an NP-F battery to power the device, DJI SDR Transmission also supports a USB-C power supply. Connect the PD adapter to the USB-C power and gimbal communication port on the transmitter or the USB-C power port on the receiver using a USB-C cable to power the device.

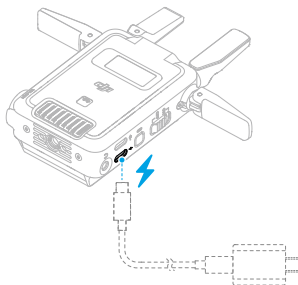

Refer to the [PD Adapter Compatibility List](#) to select an appropriate adapter.

2.3 Power Supply via Gimbal

The transmitter also supports a power supply from the gimbal, and can be used with DJI RS 4 Pro, DJI RS 4, and DJI RS 3 Pro. Taking DJI RS 4 Pro as an example, use the camera control cable (USB-C 30 cm) to connect the video transmission/LiDAR range finder port on the gimbal to the USB-C power and gimbal communication port on the transmitter. This setup allows the gimbal to power the transmitter.

-
- 💡 • DJI RS 4 and DJI RS 4 Pro do not support transmitter installation in vertical shooting mode.
-

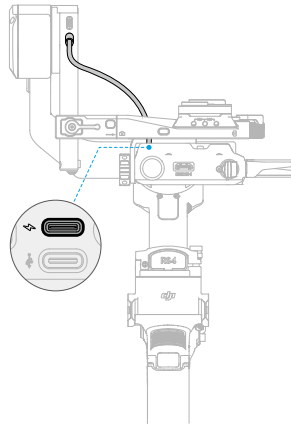

3 Firmware Update and Device Activation

After the device is powered, toggle the power switch to turn on the device. When using for the first time, select the system language.

The transmitter and receiver need to be updated and activated separately before use.

Downloading DJI Assistant 2 (Ronin Series)

Visit the DJI website and download the software to your computer.

Updating and Activating the Device

Connect the USB-C firmware update port of the transmitter or the USB-C firmware update and video output port of the receiver to the computer using a USB-A to USB-C cable, and then run DJI Assistant 2 (Ronin Series).

 DO NOT use a USB-C to USB-C cable when updating and activating the device.

Log in to your DJI Account. Click the device icon on the home page to access the firmware update page. View the current firmware version in use and all available firmware. Select the latest firmware and click **Upgrade**. DO NOT turn off the device during the update. Wait for the update to complete. Make sure the firmware version of the transmitter and the receiver are consistent. Click the device icon on the home page and follow the prompts to activate the device.

-
-  • DO NOT unplug the cable or remove the battery during the update.
- If the update fails, restart and try again.
-

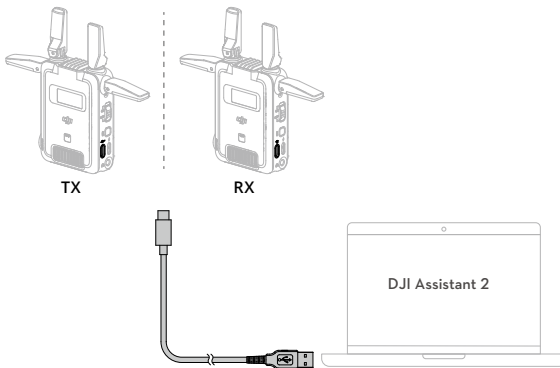

4 Touchscreen

4.1 Home Screen

Transmitter

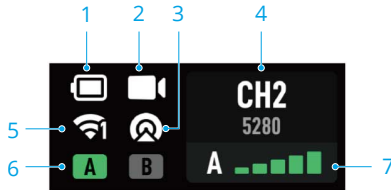

1. Battery Level

Voltage is displayed when the adapter is connected.

2. Video Signal Input Status

Indicates if there is a video source signal input or not.

3. Broadcast Mode Status

Displays whether the Broadcast mode is enabled.

4. Channel and Center Frequency

5. Wi-Fi Status

Displays the Wi-Fi connection status. The number in the lower right corner of the icon represents the number of connected devices.

6. Control Mode Status

A/B represents control device A/B respectively. Green light indicates that the device is connected.

7. Device Number and Video Transmission Signal Quality

In Broadcast mode, only the device number is displayed. In Control mode, the video transmission signal quality is additionally displayed. Green indicates a strong signal, yellow indicates a moderate signal, and red indicates a weak signal.

Receiver

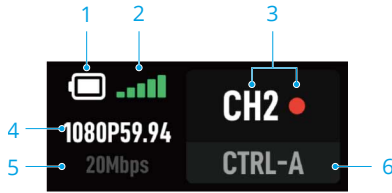

1. **Battery Level**
2. **Video Transmission Signal Quality**
Displays the quality of the signal connection between the receiver and the transmitter. Green indicates a strong signal, yellow indicates a moderate signal, and red indicates a weak signal.
3. **Channel and Channel Signal Quality**
Green indicates a strong signal, yellow indicates a moderate signal, and red indicates a weak signal.
4. **Video Specifications**
Resolution and frame rate are displayed.
5. **Video Transmission Bitrate**
6. **Control Device**
In Broadcast mode, the device number is displayed.

4.2 Menu

Slide down on the transmitter and receiver home screen to enter the menu.

Transmitter Menu

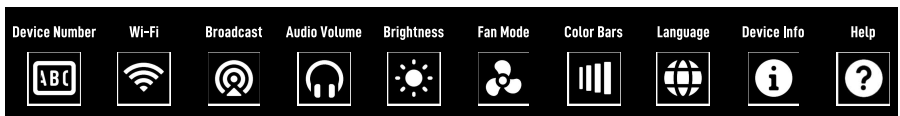

Device Number: Select a device number for the transmitter. Device numbers can be used to identify different transmitters, making it easier to distinguish between transmitters during the connection process.

Wi-Fi: Enable or disable Wi-Fi. When Wi-Fi is enabled, a Wi-Fi channel can be selected for the transmitter.

Broadcast: Enable or disable Broadcast mode. When Broadcast mode is enabled, the channel used will be displayed.

Audio Volume: Slide the bar to adjust the headset volume during communication between the transmitter and receiver.

Brightness: Slide the bar to adjust the brightness.

Fan Mode: Can be set to **Standard**, **Low**, **High** or **Rec Low**.

-
- ⚠ • Setting the fan mode to Rec Low may cause overheating.
 - When the device is overheated, the fan speed will still increase to ensure normal operation even when the fan mode has been set to Rec Low. To ensure optimal performance, operate the device within the working temperature range to prevent overheating.
-
- 📖 • Only when the transmitter is used with specific camera models can the fan mode be set to **Rec Low**. Refer to [DJI SDR Transmission Camera Compatibility List](#) for details.
-

Color Bars: When enabled, color bars will be displayed on the camera view when there is no video signal input.

Language: Tap to set the onscreen language to Chinese or English.

Device Info: Displays the firmware version and serial number of the device.

Help: Scan the QR code to access tutorial videos, common troubleshooting problems, and view firmware version information.

Receiver Menu

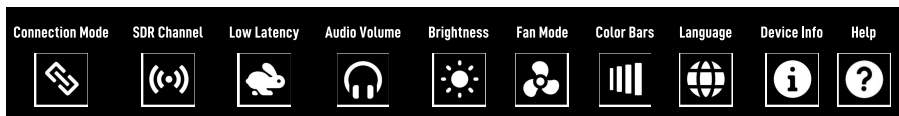

Connection Mode: Select Control mode or Broadcast mode.

SDR Channel: In Control mode, tap SDR Channel to view the channel signal quality, which is shown by the colored dots on the right. In Broadcast mode, channels can be viewed but not switched.

- Refer to the [DJI SDR Transmission Channel and Frequency Table](#) for channels supported in different countries.
- DFS channels cannot be selected if all receivers are connected to the same transmitter in Broadcast mode.

Low Latency: Enable or disable low latency mode. The frame rate will be converted to 60 fps when enabled and it will follow the camera's output frame rate when this mode is disabled. Receiver latency can be reduced to some extent.

For other functions in the receiver menu, refer to the [Transmitter Menu](#).

4.3 Channel Selection

In **Control mode**, slide up on the home screen of the transmitter and receiver to enter the SDR Channel interface for channel selection. The colored dot next to each channel on the receiver screen shows the quality of that channel.



Transmitter



Receiver

- When using only one transmitter, it is recommended to switch the channel to AUTO to enhance interference resistance and transmission performance. When the transmitter is in Broadcast mode, switching the channel to AUTO is not supported.
- When using multiple transmitters at the same time, it is recommended to manually select the channel based on the channel quality. It is recommended to select channels with lower numbers and ensure that each transmitter is set to a different channel.

In **Broadcast mode**, slide up on the transmitter home screen to access the SDR Channel interface for channel selection. Slide up on the receiver home screen to enter the Broadcast interface, allowing for the device number list to be refreshed and the selection of the connected transmitter.



Transmitter

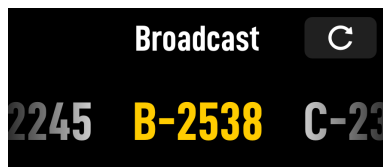

Receiver

-
- 💡 • When all receivers are connected to the same transmitter in Broadcast mode, DFS channels are unavailable.
-

4.4 Wi-Fi Connection

Slide right on the transmitter home screen to enter the Wi-Fi connection interface. Use the Ronin app to scan the QR code for quick Wi-Fi connection. Alternatively, slide up on the Wi-Fi connection interface to view the device name and password. Select Wi-Fi in the system settings of your phone or tablet, choose the device name and enter the password to complete the connection.

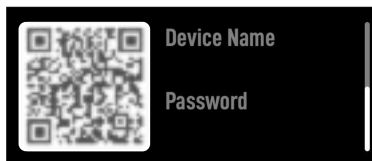

5 Connection Mode

Activation is required when using the transmitter and the receiver for the first time. Control mode, Broadcast mode, and Wi-Fi mode are supported by DJI SDR Transmission.

5.1 Control Mode

Introduction

In Control mode, you can connect one transmitter with up to two receivers, experiencing a longer video transmission distance and a stronger interference resistance. Control mode enables seamless auto frequency hopping and dynamic bitrate adjustments, meeting the demands for high-quality transmission and scenarios where one transmitter is connected to two receivers. Two-way communication via the headset is enabled between the transmitter and the receiver. Each transmitter can only communicate with one receiver.

Linking

Control mode is enabled by default. Follow these steps to link the transmitter and the receiver:

1. Slide down on the receiver home screen, tap **Connection Mode** and select **CTRL.A** or **CTRL.B** to enter the linking status.
2. Press and hold the link button on the transmitter to enter the linking status and start linking. Tap **Cancel** to terminate the process at any time during the process.

Once connected, slide up on the home screen of the transmitter or receiver to select the appropriate channel. This action can also be completed by sliding down on the receiver home screen, tapping **SDR Channel**, and then selecting the appropriate channel.



- When a transmitter and two receivers are connected in Control mode, place the receivers at least half a meter apart to avoid uplink interference.
- Minimize obstructions between the transmitter and receiver for the optimal transmission signal. Elevate the transmitter or the receiver if necessary.

5.2 Broadcast Mode

Introduction

In Broadcast mode, you can connect an unlimited number of receivers to a transmitter, but compromises on transmission range and bitrate when compared with Control mode.

It is suitable for scenarios such as TVC shootings, where a short-distance connection to multiple receivers for monitoring is needed.

Searching for a Connection

1. Slide down on the transmitter home screen to enter the menu. Select and enable Broadcast mode.
2. Slide down on the receiver home screen to enter the menu. Tap Connect and select BCST. The receiver starts searching for nearby transmitters.
3. Select the transmitter to be connected in the list of searched devices and complete linking.

Once connected, slide up on the home screen of the transmitter to select the appropriate channel.



- The transmission performance will be affected when Broadcast mode is enabled. For optimal performance, disable Broadcast mode when the transmitter connects to two or less receivers.
 - In Broadcast mode, when two receivers are installed in close proximity, it is recommended to manually set distinct channels for each receiver to avoid interference.
-

5.3 Wi-Fi

Introduction

In addition to Control mode and Broadcast mode, up to two mobile devices (smartphones or tablets) can be used to connect directly to the transmitter via Wi-Fi. Once connected, you can monitor the image via the Ronin app.



- Wi-Fi mode is not supported by the receiver.
-

Connecting to the Wi-Fi

1. Slide down on the transmitter home screen to enter the menu, select Wi-Fi and enable it.
2. Slide right on the transmitter home screen to enter the Wi-Fi connection interface.
3. Scan the QR code in the Quick Start Guide or visit <https://www.dji.com/sdr-transmission/downloads> to download the Ronin app.
4. Open the Ronin app, tap **Connect to Transmitter** and select **Scan QR Code to Connect** for quick connection. Scan the QR code to complete the connection.

Alternatively, for mobile devices with the Android system, select **Wi-Fi Connection** to search for nearby transmitters and select a transmitter from the list of searched devices.

For mobile devices with the iOS system, slide up on the Wi-Fi connection interface of the transmitter to view the device name and password. Select **Wi-Fi** in the system settings of your phone or tablet, choose the device name and enter the password to complete the connection.

The screen will automatically change to the Camera View when the connection is successful.

5.4 Recommended Connection Schemes

Scenarios	Connection Schemes
Using One Transmitter with Multiple Receivers	<p>No more than two receivers: It is recommended to disable Broadcast mode, link in Control mode, and set the SDR channel to AUTO.</p> <p>💡 Two receivers in Control mode should maintain a distance of more than 0.3 meters from each other.</p>
	<p>More than two receivers: It is recommended to enable Broadcast mode and manually select a channel. You can start by connecting one receiver and, based on its channel quality indicator, prioritize channels with a lower number that offer superior quality.</p>
Using Multiple Transmitters with Multiple Receivers	<p>Each transmitter is paired with no more than two receivers: It is recommended to disable Broadcast mode, link in Control mode, and manually select a channel.</p> <p>💡 Receivers in Control mode should maintain a distance of more than 0.3 meters from each other.</p>
	<p>Each transmitter is paired with more than two receivers: It is recommended to enable Broadcast mode and manually select a channel. You can start by connecting one receiver and, based on its channel quality indicator, prioritize channels with a lower number that offer superior quality. Additionally, ensure the channels for different transmitters are staggered to avoid using the same or adjacent channels.</p>

- In all of the above scenarios, you can decide whether or not to enable Wi-Fi and monitor the camera view via the Ronin App on their mobile devices.
-

6 Ronin App

Using the Ronin app, you can experience monitoring assistance tools and functions such as gimbal control and camera control on smartphones or tablets, enjoying a more convenient and intuitive operation experience. You can log in to your accounts to sync the footage to the Filming app. DJI SDR Transmission can be used with DJI RS 4 Pro, DJI RS 4, DJI RS 3 Pro. This section takes DJI RS 4 Pro as an example to show you how to use it and precautions.

6.1 Downloading Ronin App

Scan the QR code in the Quick Start Guide or visit <https://www.dji.com/sdr-transmission/downloads> to download the Ronin app.

6.2 Installation and Connection

To use the transmitter with a camera and a gimbal, follow the steps below to install and connect the devices.

1. Remove the TX gimbal mounting adapter plate from the packaging, install the adapter plate on the bottom of the transmitter, and tighten the screws.
2. Mount the transmitter to the camera mounting plate of DJI RS 4 Pro via the cold shoe on the adapter plate.
3. Connect the video transmission/LiDAR range finder port on the gimbal to the USB-C power and gimbal communication port on the transmitter using the camera control cable (USB-C, 30 cm). This setup allows the gimbal to power the transmitter.
4. Connect the HDMI or SDI input port of the transmitter with the video signal port (HDMI or SDI port) of the camera using a transmission signal cable (HDMI or SDI cable).



- The transmitter features a standard HDMI port (Type A). A compatible HDMI cable for the camera needs to be purchased.
- When DJI RS 4 and DJI RS 4 Pro are configured for vertical shooting, the TX gimbal adapter plate cannot be attached to mount a transmitter.

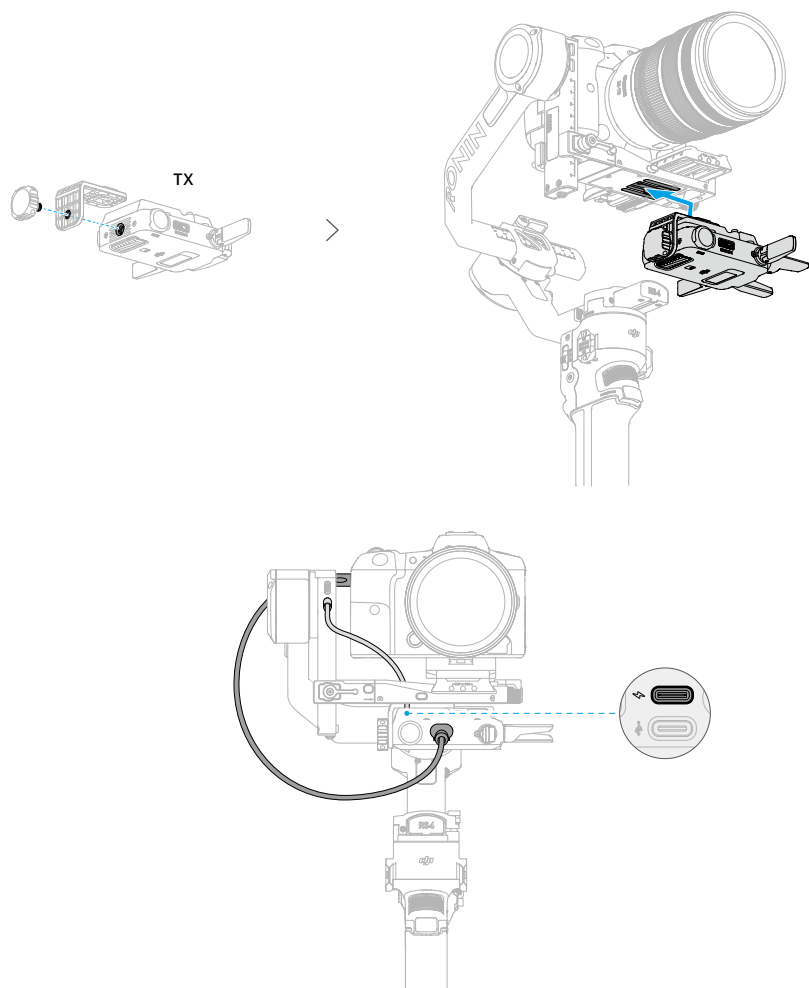

6.3 Connecting to Transmitter

The Ronin app can be connected to DJI SDR Video Transmission via SDR or Wi-Fi.

Wi-Fi Connection

1. Slide down on the transmitter home screen to enter the menu, select Wi-Fi and enable it.

- Slide right on the transmitter home screen to enter the Wi-Fi connection interface.
- Open the Ronin app, tap **Connect to Transmitter** and select **Scan QR Code to Connect** for quick connection. Scan the QR code to complete the connection.

Alternatively, for mobile phones with the Android system, select **Wi-Fi Connection** to search for nearby transmitters and select a transmitter from the list of searched devices.

For mobile phones with the iOS system, slide up on the Wi-Fi connection interface of the transmitter to view the device name and password. Select **Wi-Fi** in the system settings of your phone or tablet, choose the device name and enter the password to complete the connection.

The screen will automatically change to the Camera View when the connection is successful.

-
- It is recommended to disable the Bluetooth on your mobile device before connecting to the transmitter via Wi-Fi.
-

SDR Connection

Connect the transmitter and receiver in Control mode or Broadcast mode, and then connect the USB-C firmware update and video output port of the receiver to the smartphone using the RX to phone connection cable. Open the Ronin app to monitor the camera view.

6.4 Camera View

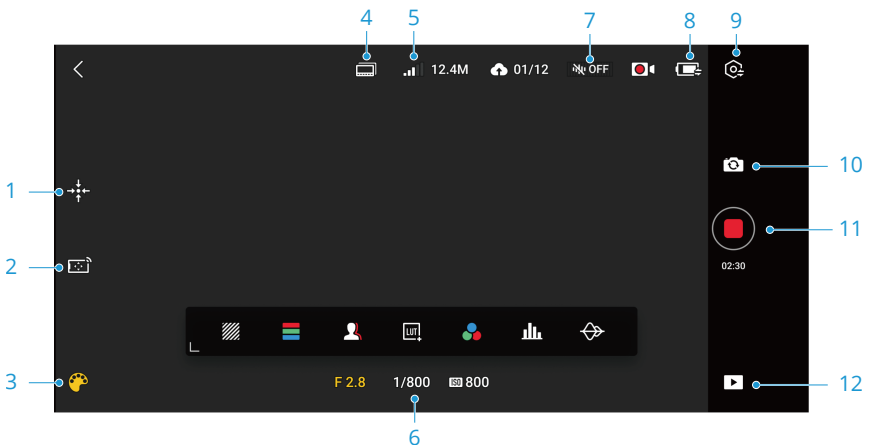

Tap the screen to enter Clear mode and tap again to exit.

1. Gimbal Recenter

Tap to recenter the gimbal.

2. Virtual Joystick/Force Mobile

Enable or disable virtual joystick/force mobile and adjust the settings.

Virtual Joystick: Tap to enable or disable virtual joystick. Control the speed and smoothness of the gimbal by adjusting the control bar. When virtual joystick is enabled, a joystick for the pan and tilt axes will appear in the bottom left corner of the camera view. By default, move the joystick left and right to control the pan axis, and up and down to control the tilt axis. A joystick for the roll axis will appear in the bottom right corner of the screen. Move the joystick left and right to control the roll axis.

Force Mobile: Tap to enable or disable force mobile. When enabled, the gimbal movement can be controlled by tilting and rotating your phone or tablet. The gimbal movement cannot be controlled by rolling the mobile phone by default.

3. Assistant

Tap to choose assistance tools, including zebra stripes, false color and others.

Zebra Stripes: When enabled, the overexposed areas in the image will be displayed in black and white stripes.

False Color: When enabled, colors representing exposure values of different objects will be added to the image.

Focus Peaking: When enabled, you can set the display color and percentage for color peaking or the percentage for aperture peaking.

LUT: Tap to enable or disable the LUT display. When enabled, you can apply preset LUT effects directly to the image. LUT files can be shared with the Ronin app via a file manager or a third-party app, after which you can tap **Custom** to select the desired LUT.

Single Color: Select a color and display the transmission screen in that color, with all color information represented in contrast.

Histogram: When enabled, the brightness distribution of the camera view will be displayed. Histogram helps determine the exposure of the image.

Waveform: When enabled, the waveform representing the current image brightness and darkness relationship is displayed in a floating window. Move the waveform to avoid obstructing the view.

4. Camera Position Switching

5. Channel Switching

When the phone or tablet is connected to the transmitter via Wi-Fi, tap here to switch channels. When connected to the receiver via SDR in Control mode, tap here to switch

channels. In Broadcast mode, channels can be viewed but not switched. To change camera positions, tap the icon on the left of the channel switching icon.

6. Shutter, Aperture, and ISO

When the transmitter is connected to a camera supporting PTP control and the camera is configured, the shutter, aperture, and ISO parameters can be adjusted here.

For example, with a Sony FX3, follow the steps below:

- a. Connect the camera to the USB-C firmware update port of the transmitter using a USB-C to USB-C cable.
- b. In the camera menu, select **Network > Transfer/Remote > PC Remote Function** and enable it.



- These steps are for reference only. Refer to the actual interface for instructions.
-

7. Volume

Displays the volume of the current input source video.

8. Battery Level

Displays the battery level of the connected transmitter.

9. Settings

Assistant: Enable or disable the monitoring assistance tools.

Zebra Level: Adjust the brightness threshold for displaying black and white stripes to fine-tune the exposure.



Focus Assist: Adjust the focus peaking threshold to confirm the clearest focus area in the image.

Composition: Adjust the type of guide frame, aspect marker, safety zone marker, center marker, marker color, and marker width.

General:

Channel Settings

When the phone or tablet is connected to the transmitter via Wi-Fi, tap here to switch channels. When connected to the receiver via SDR in Control mode, tap here to switch channels. In Broadcast mode, channels can be viewed but not switched.

Camera Control Button	<p>Tap to enter the camera control interface and operate the camera menu via the Ronin app. Ensure the camera is pre-configured with the correct HDMI output settings and CEC enabled.</p> <p>For example, with a Sony FX3, follow the steps below:</p> <ol style="list-style-type: none">Enter the camera menu of Sony FX3 and select Setup > External Output to configure the HDMI output parameters, such as resolution.Select HDMI Control and enable it. <p> These steps are for reference only. Refer to the actual interface for instructions.</p> <p> Refer to the DJI SDR Transmission Camera Compatibility List for supported camera models.</p>
Cache Settings	<p>Set the shutter options and max cache.</p> <p>Shoot: Tap the shutter button and the camera will start shooting.</p> <p>Cache: The mobile device starts caching footage after tapping the shutter button. No footage is saved on the camera memory card.</p> <p>Shoot + Cache: The camera and mobile device start shooting and caching footage simultaneously.</p> <p>Max cache can be set to 1GB, 2GB, 4GB, 8GB, or no limit.</p>
Wi-Fi Settings	Change Wi-Fi name and password.
Filming App	After logging into the Filming app, you can input shooting projects and switch camera positions. After enabling Auto Sync Cache Files , new cache files in the Ronin app will be synchronized to the Filming app. Tap Upload History to manage synchronized footage. In Network Setting , Sync over Cellular Data can be enabled or disabled.
About	Displays the serial number and the firmware version.

10. Photo/Video

Tap to switch between photo and video modes.

11. Shutter/Record Button

Tap to take photos in photo mode and tap to start recording in video mode.

12. Playback

Tap to view cached photos and videos.

7 Accessories

DJI SDR Transmission can be used with the TX gimbal mounting adapter plate, TX camera mounting adapter plate, phone holder, and tablet holder. The TX gimbal mounting plate can attach the transmitter to the gimbal horizontal plate of DJI RS 4 Pro, DJI RS 4, and DJI RS 3 Pro. For installation instructions, refer to the [Ronin App](#) section. This section introduces the installation and use of the TX camera mounting adapter plate, phone holder, and tablet holder.

7.1 TX Camera Mounting Adapter Plate

The transmitter can be mounted to the camera cage using the TX camera mount adapter plate for convenient placement during use.

Installation

Remove the TX camera mounting adapter plate from the packaging. Insert and tighten one of the adapter plate screws into the bottom hole of the transmitter, then insert and tighten the other screw into the camera cage hole.

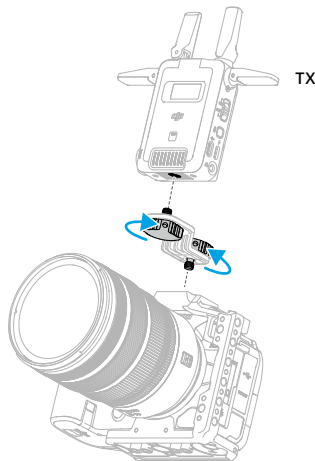

7.2 Phone Holder (Sold Separately)

The phone holder supports quick mounting of the phone and video transmission receiver. The phone clamp has a cold shoe port on both sides. A cold shoe and a 1/4" screw hole on the bottom of the phone holder allows for mounting on a tripod.

Installation

1. Open the phone clamp ①, place the phone in the center of the clamp ②.
2. Screw the tripod into the 1/4" screw hole at the bottom of the holder ③.
3. Mount the receiver to the phone holder and tighten the screw ④ on the bottom of the receiver.
4. Use the RX to phone connection cable (USB-C to USB-C) to connect the phone to the USB-C firmware update and video output port of the receiver.

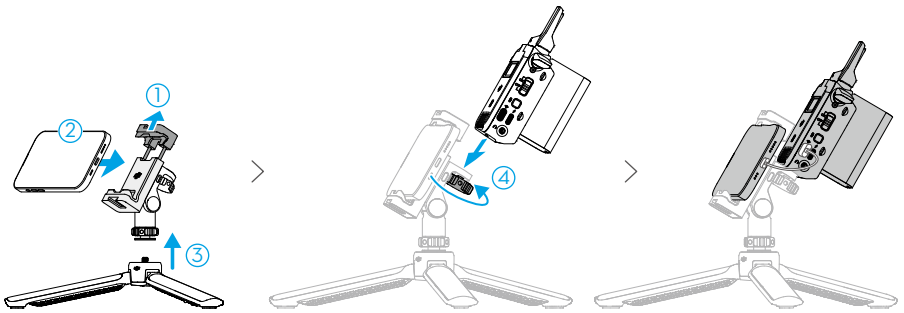

The pitch angle of the holder can be adjusted up to 90°, and the phone clamp can rotate 90°, allowing for horizontal and vertical shooting. When switching from horizontal to vertical shooting, press and hold the unlock button on the side of the holder before rotating the phone clamp to the desired position.



7.3 Tablet Holder (Sold Separately)

The tablet holder can hold both a tablet and a video transmission receiver at the same time, making it easy for users to view the video transmission from the camera in real time. The back of the tablet clamp is equipped with several 1/4" screw holes for mounting extended handles.

Installation

1. Loosen the screw ① on the tablet clamp and open the clamp.

2. Place the tablet into the center of the clamp ②, and then tighten the screw ③.
3. Mount the receiver to the tablet holder and tighten the screw ④ on the bottom of the receiver.
4. Unfold the stand ⑤. Use the RX to phone connection cable (USB-C to USB-C) to connect the tablet to the USB-C firmware update and video output port of the receiver.

💡 The stand of the tablet holder only supports unfolding to a fixed position (approximately 60°) and does not support angle adjustment. DO NOT adjust the angle of the stand with force to avoid causing damage to the structure of the holder.

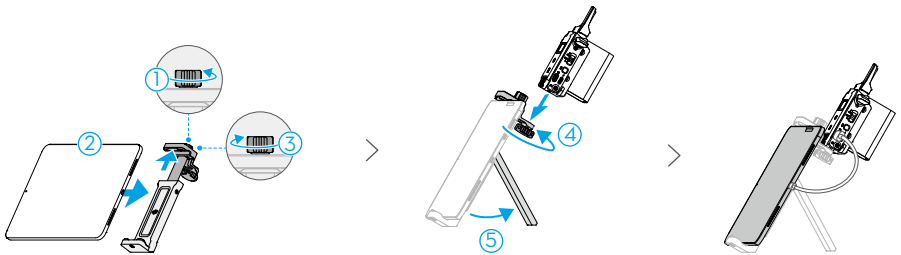

8 Specifications

	Transmitter	Receiver
Weights	Approx. 145 g (including antennas)	
Dimensions	86.5 mm×64 mm×32 mm (L×W×H, excluding antennas)	
Video Transmission System	SDR + Wi-Fi	SDR
Operating Frequency	SDR Operating Frequency Non-DFS Frequency Band: 2.4000-2.4835 GHz 5.725-5.850 GHz DFS Frequency Band ^[1] : 5.470-5.725 GHz Wi-Fi Operating Frequency 2.4000-2.4835 GHz 5.150-5.250 GHz	SDR Operating Frequency Non-DFS Frequency Band ^[2] : 2.4000-2.4835 GHz 5.725-5.850 GHz
Transmitter Power (EIRP)	SDR: 2.4000-2.4835 GHz: < 30 dBm (FCC) < 20 dBm (SRRC/CE/MIC) 5.470-5.725 GHz: < 30 dBm (FCC) < 23 dBm (CE/MIC) 5.725-5.850 GHz: < 30 dBm (FCC) < 14 dBm (CE) < 30 dBm (SRRC) Wi-Fi: 2.4000-2.4835 GHz: < 26 dBm (FCC) < 20 dBm (SRRC/CE/MIC) 5.150-5.250 GHz: < 26 dBm (FCC) < 23 dBm (SRRC/CE/MIC)	SDR: 2.4000-2.4835 GHz: < 30 dBm (FCC) < 20 dBm (SRRC/CE/MIC) 5.725-5.850 GHz: < 30 dBm (FCC) < 14 dBm (CE) < 23 dBm (SRRC)
Wi-Fi Protocol	802.11b/a/g/n/ac/ax Supports 2×2 MIMO Wi-Fi	/

	Transmitter	Receiver
Max Bandwidth	SDR: 20 MHz Wi-Fi: 20 MHz	SDR: 20 MHz
Max Bitrate	SDR: 20 Mbps ^[3] Wi-Fi: 8 Mbps	SDR: 20 Mbps ^[3]
Power Consumption ^[4]	8.2 W	8.3 W
Power Supply	USB-C Power Supply Type 1: 9 V, 2 A (PD protocol) USB-C Power Supply Type 2: 6.8-17.2 V DC NP-F Battery Power Supply Voltage: 6.8-8.4 V	
Input Video Format	1080p: 23.98/24/25/29.97/30/50/59.94/60fps 1080i: 50/50.94/60fps (1080i is not available in Broadcast mode). 720p: 50/59.94/60fps	
Input Audio Format	SDI embedded, HDMI embedded	PCM
Video Transmission Latency	SDR ^[5] : 80 ms (including camera and screen display latency) 35 ms (excluding camera and screen display latency) Wi-Fi ^[6] : 110 ms	SDR ^[5] : 80 ms (including camera and screen display latency) 35 ms (excluding camera and screen display latency)
Video Coding Format	H.264	
Max Transmission Distance	SDR ^[3] : 3 km (FCC) 2 km (CE/SRRC/MIC) Wi-Fi: 200 m	SDR ^[3] : 3 km (FCC) 2 km (CE/SRRC/MIC)
Operating Temperature	-10° to 40° C (14° to 104° F)	

[1] 5.8 GHz is prohibited in some countries/regions. Check local laws and regulations for more information. 5.600-5.650 GHz is not used.

[2] 5.600-5.650 GHz is not used.

[3] Measured in Control mode, with Broadcast mode turned off.

[4] Measured at a room temperature of 25° C (77° F), when linked in Control mode, at a distance of approximately 10 meters, in a 1T1R setup, with Wi-Fi turned off, using PD for power supply.

[5] Measured when shooting 1080p/60fps video with Broadcast mode turned off.

[6] Measured when shooting 1080p/60fps video.



The terms HDMI, HDMI high Definition Multimedia Interface, and

the HDMI Logo are trademarks or registered trademarks of HDMI Licensing Administrator, Inc.

WE ARE HERE FOR YOU



This content is subject to change without prior notice.



<https://www.dji.com/sdr-transmission/downloads>

If you have any questions about this document, please contact DJI by sending a message to DocSupport@dji.com.

DJI is a trademark of DJI.

Copyright © 2024 DJI All Rights Reserved.