

SHIMBOL

Video Recording Monitor Memory 7 PRO



Instruction Manual
Shenzhen ZO Video Technology Co., Ltd.

Packing list

Carry Case



Monitor



Tempered Screen Protector



User Manual



HDMI Cable

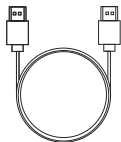

SDI Cable

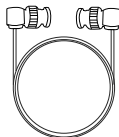

Hot Shoe Mount

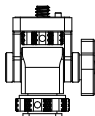

Dusting Cloth



SD card



Carry Case*1

Monitor*1

Tempered Screen
Protector*1

User Manual*1

HDMI Cable*1

SDI Cable*1

Hot Shoe Mount*1

Dusting Cloth*1

SD card*1

Buttons And Ports

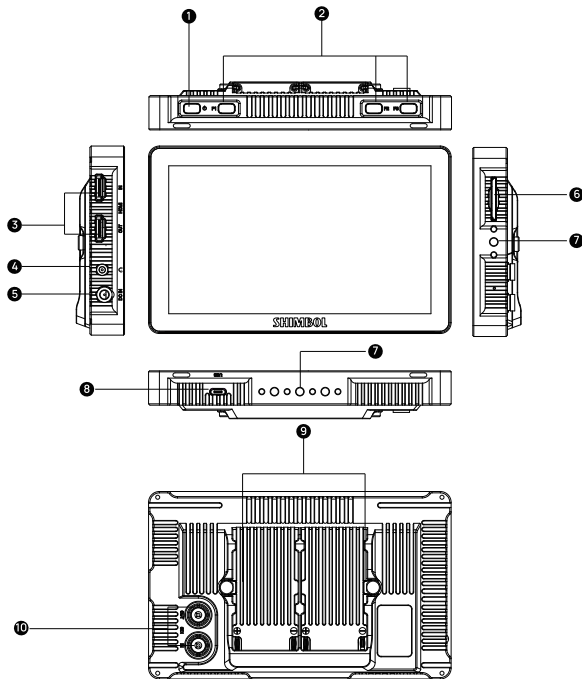

- 1 Power ON/ OFF Button
- 2 Custom Function Buttons
- 3 HDMI Interfaces
- 4 3.5mm Headphone Jack
- 5 DC Input
- 6 SD Card Slot
- 7 1/4"-20 Thread Hole
- 8 USB Upgrade Port Hole
- 9 NP-F Battery Plate
- 10 SDI Interfaces

I . Monitors Assist Icons



Switching
Signal



Input

HDMI-SDI



Scope Menu



Waveform

shows the levels
of brightness from an
input source



RGB-Paral

monitor the
level of red,
green and blue
from an input
source



Histogram

this is useful for
checking if an image
is under or over
saturated.



Vector

visualize the
dynamic
range of
your image



Marker Menu



Marker

mark through
your chosen
aspect ratio



Safe area

action area
and title safe
areas displayed



Anamorphic

allows you to
see a correctly
squeezed image
when using
anamorphic lenses



Center marker

mark image
center



Matte

Multiple modes
are available



Grid

Multiple lines
are selected

I . Monitors Assist Icons



Focus Menu



Peaking

ensure your recordings are always in focus



Zoom

zoom in image



Exposure Menu



Zebra

use zebra to check exposure and set exposure levels



False color

a visualization of exposure across the image



Monochrome

monochrome display mode



Color Menu



3D-LUT

3D-LUT loading & updating



Gamma

gamma setting



HDR

HDR monitoring



Color temperature

color temperature setting

Catalog

| | |
|-----------------------------------|----|
| I . Monitors Assist Icons----- | 2 |
| II . User Interface ----- | 5 |
| III. Operation Guide ----- | 8 |
| 1. Boot Method ----- | 8 |
| 2. RGB Gain and Offset----- | 8 |
| 3. Format SD Card ----- | 9 |
| 4. Shortcut Key Preset----- | 9 |
| 5. High Precision Waveform----- | 10 |
| 6. Matte ----- | 10 |
| 7. Peaking ----- | 11 |
| 8. HDR Monitoring----- | 11 |
| 9. 3D-LUT Input Method ----- | 12 |
| 10. 3D-LUT Output Method ----- | 13 |
| 11. DCI-P3 ----- | 13 |
| 12. Recording And Playback ----- | 14 |
| IV. Notes----- | 15 |
| 1. Exceptions in Connection ----- | 15 |
| 2. SD card Description----- | 15 |
| 3. Record and Playback----- | 15 |
| V. Technical Parameters----- | 16 |

II . User Interface



- 1 Video Input
- 2 Resolution
- 3 Zoom
- 4 SD Card
- 5 3D-LUT
- 6 Power Indication
- 7 Switching Signal
- 8 Waveform Menu
- 9 Marker Menu
- 10 Focus Menu
- 11 Exposure Menu
- 12 Color Menu
- 13 Recording and playback
- 14 System Settings
- 15 Lock Screen
- 16 Playback Button
- 17 Audio Meter
- 18 REC Button

II . User Interface



Switching Signal



Scope Menu



Marker Menu



Focus menu



Exposure menu



Color menu

II . User Interface



Recording and Playback Menu

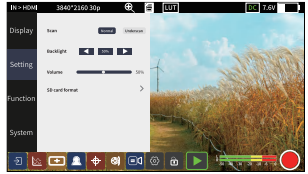

System Settings Menu



Lock Screen

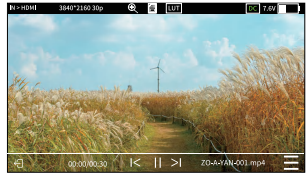

Playback

III. Operation Guide

1.Boot Method

Short press the power on/off button to turn on the monitor, long press 3 seconds to turn it off.

2.RGB Gain and Offset

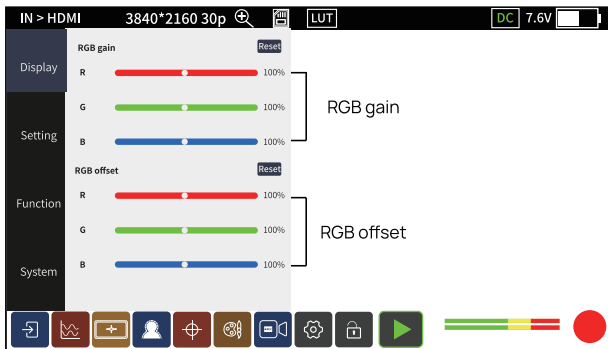

III. Operation Guide

3.Format SD Card

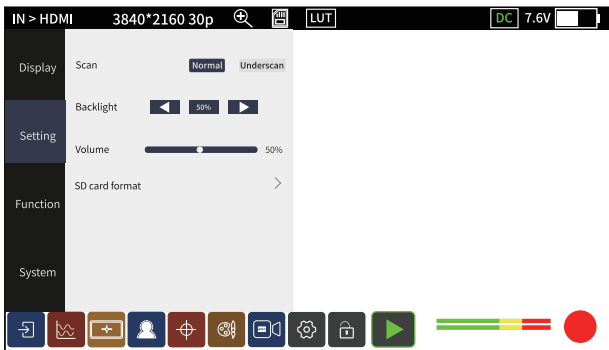

4.Shortcut Key Preset

There are two shortcut keys, F1 and F2. F3, on the top of the host, and you can choose function presets.

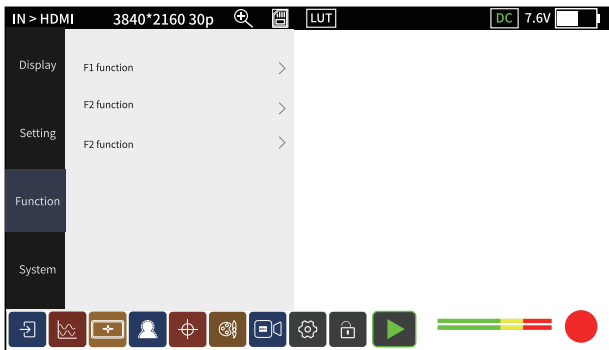

III. Operation Guide

5.High Precision Waveform

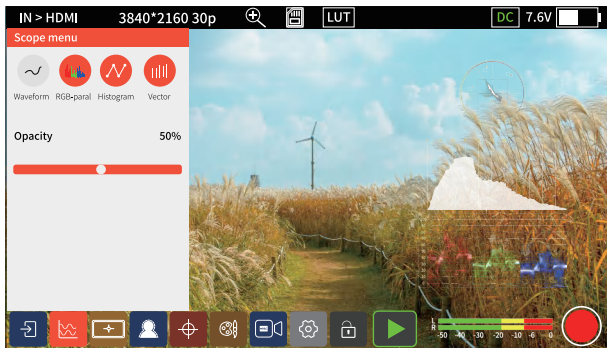

6.Matte

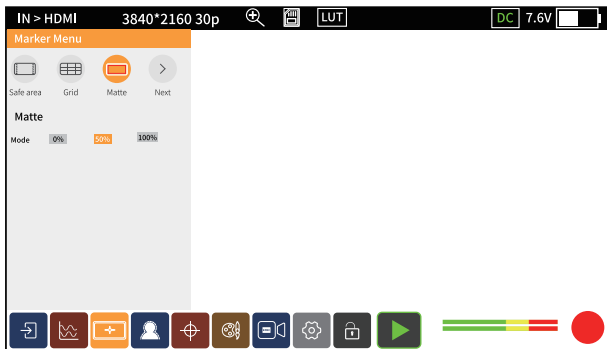

III. Operation Guide

7. Peaking

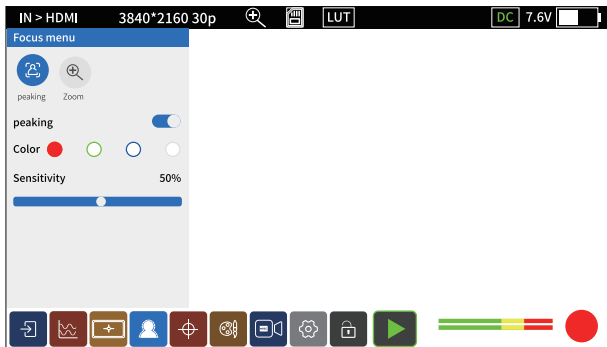

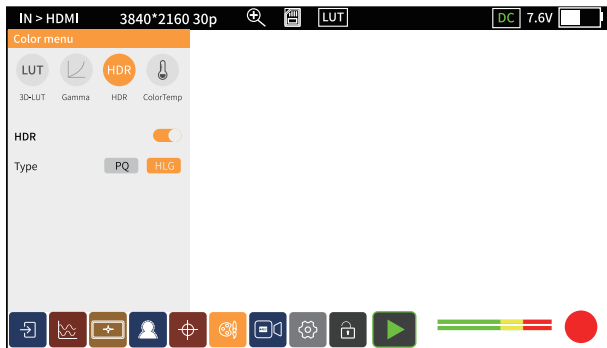

8. HDR Monitoring

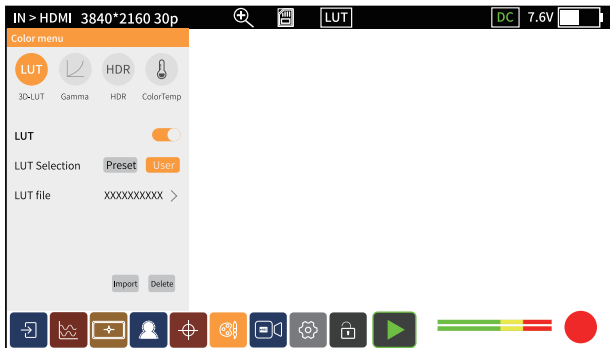

III. Operation Guide

9.3D-LUT Input Method



- 1 Place the LUT file in the LUT folder on the SD card and insert the SD card into the monitor
- 2 Click the Color Menu-3D-LUT, turn on , and then selecting Custom, click the Import button and wait for the system to retrieve the LUT file in the SD card that needs to be loaded
- 3 Click on the LUT file that needs to be loaded, then click Import and wait for the file to be imported into the system
- 4 Click the LUT file, enter the file selection, select the desired LUT, and click to confirm that the LUT is loaded successfully

Note: LUT file name only support English, do not allow any other languages , special characters, spaces, otherwise it will fail to be imported !

III. Operation Guide

10.3D-LUT Output Method

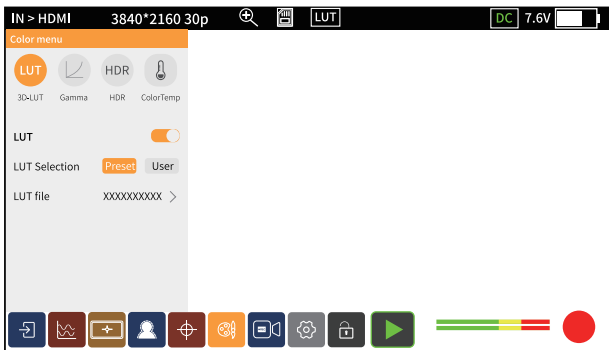

- 1 Click the color management-3D-LUT icon, open X select the corresponding LUT file, and the preset LUT color adjustment effect can be recorded into the file synchronously during recording.
- 2 The LUT for HDMI/SDI output is the same as the LUT that is turned on.

11.DCI-P3

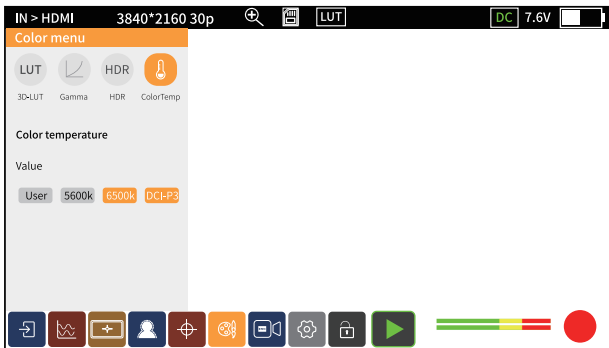

III. Operation Guide

12. Recording Playback: Custom File Name

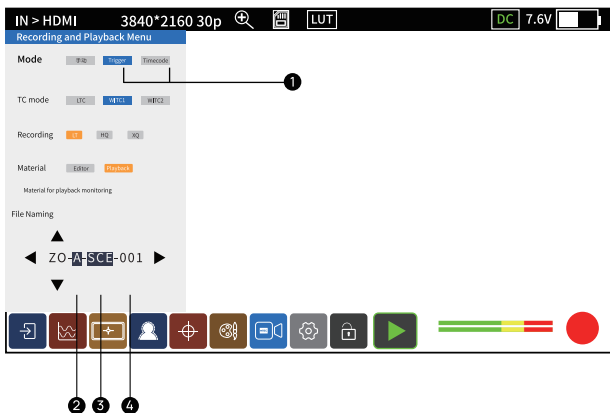

- 1 Trigger/TimeCode camera synchronization recording function
- 2 This position represents the camera position, click up and down to adjust
- 3 This position represents the shooting site, click up and down to adjust
- 4 This position represents the number of cameras, it is not adjustable and the digital number increases with the number of shootings

IV. Notes

1. Exceptions in Connection

- a. Zoom, Anamorphic, Waveform, these three functions can only be opened one at a time. Such as when the Anamorphic function is open, has opened the Zoom or Waveform will be forced to close.
- b. When HDMI IN, there is no SDI output. When SDI IN, both HDMI and SDI can be output.

2. SD Card Description :

SD Card Identification and Use Problems

- a. The SD card of this product does not support hot-swapping, if the SD card is inserted and removed during use, causing abnormalities such as the card cannot be recognized and the screen interface cannot be operated, please restart the device.
- b. The newly purchased SD card has to formatting by monitor's "SD Card Format" function before normal use.
- c. The recommended capacity of SD card is 32G-128G

3. Record and Playback

The Abnormal Phenomenon of Using Recording and Playback : Synchronous recording (Trigger/TimeCode)

- a. The camera needs to support HDMI Trigger/TimeCode
- b. Trigger/TimeCode function is turned on
- c. When recording video using 1080I60/50, the format of the recorded video will be converted to 1080P30/25.

V. Technical Parameters

| | |
|------------------------|---|
| Model No. | Memory 7 PRO |
| Screen Size | 7"TP |
| Screen Resolution | 1920*1080 |
| Aspect Ratio | 16:9 |
| Brightness | 2200nits |
| Color Gamut | DCI-P3 |
| Contrast Ratio | 1800: 1 |
| Viewing Angle | 170° (H/V) |
| Output Interface | HDMI output, SDI output, 3.5mm Headphone output |
| Input Interface | DC In , HDMI input, SDI input, SD Card Slot |
| Video Recording Format | MP4(SD card format exFAT) ^① |
| LUT Format | cube file (17*17*17 and 33*33*33) ^② |
| Audio Frequency | 48kHz |
| Power Supply Method | NP-F / DC IN |
| Input Voltage | DC7-16V |
| Power Consumption | < 10W |
| Firmware Updates | SD card updates |
| HDMI&SDI-Lut Output | support |
| Material | CNC aluminum alloy shell |
| Product Color | black |

V. Technical Parameters

| | |
|----------------------------|--|
| HDMI Input Signal Formats | 4096*2160P25/24/23.98 |
| | 3840*2160P30/23.98/25/24/23.98 |
| | 1920*1080p60/59.94/50/30/29.97/25/24/23.98 |
| | 1920*1080i60/59.94/50 |
| | 1280*720p60/59.94/50 |
| SDI Input Signal Formats | 1920*1080p60/59.94/50/30/29.97/25/24/23.98 |
| | 1920*1080PSF30/29.97/25/24/23.98 |
| | 1920*1080i60/59.94/50 |
| | 1280*720p60/59.94/50 |
| HDMI Output Signal Formats | 1920*1080p60/50/30/25/24 |
| | 1920*1080i60/50 |
| | 1920*p60/50 |
| SDI Output Signal Formats | 1080p60/50/30/25/24/ |
| | 1080i60/50 720p60/50 |
| | support SDI-LOOP OUT mode |
| Weight | 455g |
| Unit Size | 178.8*110.8*20.3/28.3mm |

Please-note:

- ① Recording file,It is under "Video" folder of root directory in SD card.
- ② The LUT file to be imported,It is under "Lut" folder of root directory in SD card, and the LUT files should not exceed 50.

SHIMBOL

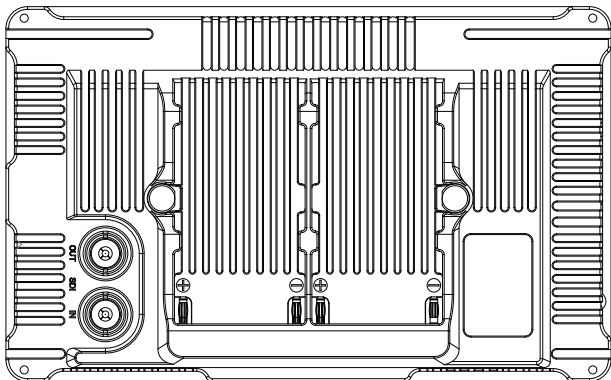

Tel+86 0755-21004986

URL:www.zeroone-video.com

Address:2C, 2nd Floor, Building 6, Longbi Industrial Park
No.27 Dafa Road, Bantian Street, Longgang District, Shenzhen
Shenzhen ZO Video Technology Co., Ltd.